

N20 DIGITAL PANEL METER

FEATURES:



- Measurement of voltage or d.c. current and temperature (Pt100, J, K):
- Three-colour LED display (5 digits, 14 mm high).
- 2 alarm outputs of OC type.
- Galvanic separation between the supply, measuring inputs and the programmer input.
- Programmable parameters through the PD14 programmer:
 - recounting of indications (individual characteristic),
 - two alarms of OC type operating in 6 working modes,
 - display colour programmable in three intervals,
 - thresholds of displayed overflows,
 - highlight of the unit,
 - automatic or manual compensation: temperature of cold ends (for J, K) or wire resistance (for Pt100),
 - measurement averaging time.
- Supply of object transducers.

INPUTS:

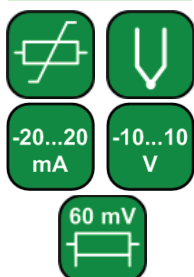

EXAMPLE OF APPLICATION

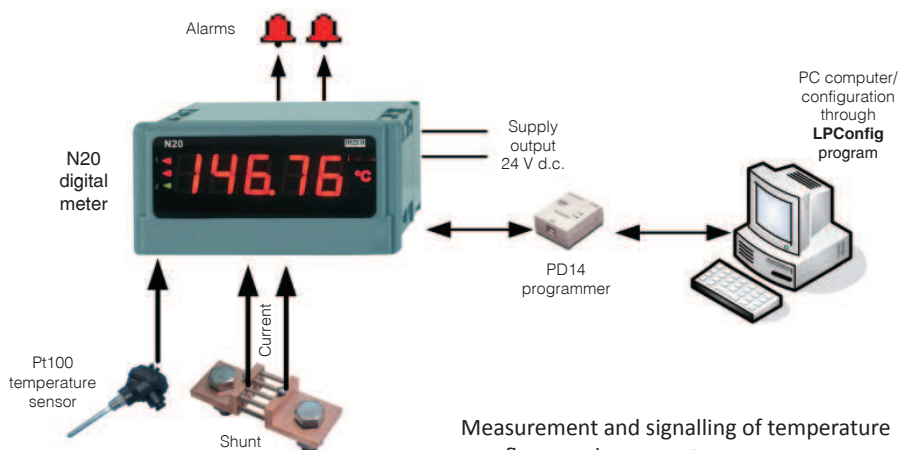

OUTPUTS:

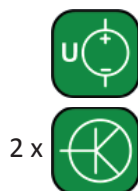

GALVANIC ISOLATION:



INPUTS

Kind of inputs	Measuring range	Parameters	Basic error
Voltage input	-11...-10...60...66 mV -1...0...10...11 V -11...10...10...11 V	Input resistance: >1 MΩ	± (0.2% of range + 1 digit)
Current input	-1...0...20...22 mA 3,6...4...20...22 mA -22...-20...20...22 mA	Input resistance: 10 Ω ± 1% Input resistance: 10 Ω ± 1% Input resistance: 5 Ω ± 1%	
Temperature measurement Pt100	- 50...400°C		
Temperature measurement through J thermocouple	- 50...1200°C		
Temperature measurement through K thermocouple	- 50...1370°C		

OUTPUTS

Kind of inputs	Features
Alarm outputs	• 2 alarm outputs of OC type
Outputs for external supply of transducers	• 24 V ± 5%, 30 mA

EXTERNAL FEATURES

Readout field	5 digital LED displays. Indication range -19999...99999 Digit height: 14 mm	Three-colour display (changes of colour depend on the displayed value): red, green, orange.
Weight	< 0.25 kg	
Overall dimensions	96 × 48 × 64 mm	Panel cut-out: 92 ^{+0,6} × 45 ^{+0,6} mm
Protection grade (acc. to EN 60529)	From frontal side: IP65	From terminal side: IP10

N20 DIGITAL PANEL METER

RATED OPERATING CONDITIONS

Supply voltage	85...253 V a.c. (45...65 Hz) or d.c., 20...40 V a.c. (45...65 Hz) or d.c.	Power consumption < 6 VA
Temperature	Ambient: -10...23...55°C	Storage: -25...85°C
Relative humidity	< 95%	Condensation inadmissible
Operating position	any	

SAFETY AND COMPATIBILITY REQUIREMENTS

Electromagnetic compatibility	noise immunity	acc. to EN 61000-6-2
	noise emissions	acc. to EN 61000-6-4
Safety requirements		acc. to EN 61010-1
Galvanic isolation between supply and measuring input	3.2 kV d.c.	

CONNECTION DIAGRAMS

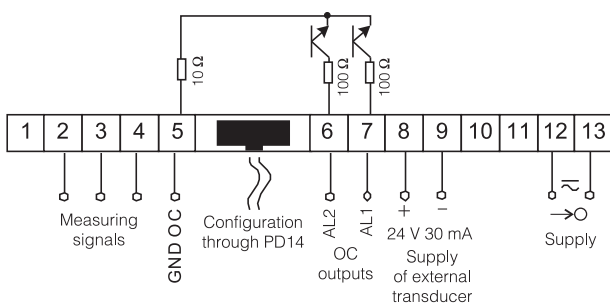

Fig. 1 Electrical connections of N20 meter.

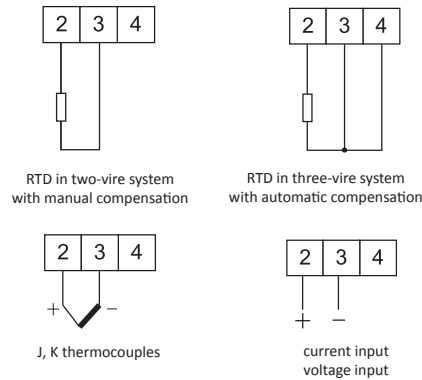

Fig. 2 Connections of measuring inputs.

ORDERING

TABLE 1. ORDERING CODES:

	N20 -	X	X	XX	XX	X
Input:						
Pt100: -50...400°C		1				
Thermocouple J: -50...1200°C		2				
Thermocouple K: -50...1370°C		3				
0...20 mA		4				
4...20 mA		5				
± 20 mA		6				
0...60 mV		7				
0...10 V		8				
± 10 V		9				
Supply:						
85...253 V a.c./d.c.			1			
20...40 V a.c./d.c.			2			
Unit:						
unit code number acc. to table 2				XX		
Version:						
standard						00
custom-made*						XX
non-standard settings						99
Acceptance tests:						
without extra requirements						8
with an extra quality inspection certificate						7
acc. to customer's request*						X

* - after agreeing with the manufacturer

TABLE 2. CODES OF HIGHLIGHTED UNIT:

Code	Unit	Code	Unit	Code	Unit
00	without unit	17	μm	34	bar
01	V	18	mm	35	rad
02	A	19	cm	36	Ω
03	mV	20	m	37	kΩ
04	kV	21	km	38	%
05	MV	22	l	39	°
06	mA	23	l/s	40	turns
07	kA	24	l/h	41	rps
08	MA	25	ms	42	rpm
09	°C	26	s	43	rph
10	°F	27	h	44	m/h
11	K	28	N	45	km/h
12	Hz	29	kN	46	imp
13	kHz	30	Pa		
14	Ah	31	hPa		
15	kAh	32	kPa	XX	on order ¹⁾
16	m/s	33	MPa		

1) - after agreeing with the manufacturer

Highlight of the measured value	ON
Automatic compensation of terminal temperature	OFF
Manual compensation of terminal temperature	0
Averaging time	1 s
Upper overflow of measurement	99999
Lower overflow of measurement	-19999
Individual characteristic	ON
Parameter <i>a</i> of the individual characteristic	10.0
Parameter <i>b</i> of the individual characteristic	0
Kind of the alarm output 1 operation	ON
Upper value to switch the alarm 1 - Aon	40.00
Lower value to switch the alarm 1 - Aoff	0.00
Delay of the alarm 1 switching time	0 second
Kind of the alarm output 2 operation	n-on
Upper value to switch the alarm 2 - Aon	44.00
Lower value to switch the alarm 2 - Aoff	40.00
Delay of the alarm 2 switching time	0 second

- means: N20 meter with current input on 4...20 mA, supply: 20...40 V a.c./d.c., executed acc. to given detailed parameter description by the user, without extra quality requirements

Caution! When ordering a meter with parameters different than standard, one must give values of **ALL** parameters.

SEE ALSO:



Free LPConfig program for programming.



PD14 programmer - unit for programming with USB connection, LPConfig compatible.



N30 digital panel meters with 3-colour display.



N24 digital panel meters with 4 digits.



N25 digital panel meters with 5 digits.

ORDER EXAMPLES

Example 1

The code **N20 - 9 1 01 00 8** - means: N20 meter with voltage input on ± 10 V, supply: 85...253 V a.c., without extra quality requirements, „V“ unit

Example 2

The code **N20 - 5 2 38 99 8** + description of non-standard settings

Parameter	Range/Value
Displayed colour of the upper measured value	red
Displayed colour of the median measured value	green
Displayed colour of the lower measured value	orange
Upper threshold - KpH	44.00
Lower threshold - KpL	40.00
Decimal point	000.00